



OZ Optics

shop.ozoptics.com
www.ozoptics.com

219 Westbrook Road
Ottawa, ON, Canada, K0A 1L0

Toll-free: 1-800-361-5415
Telephone: 1-613-831-0981
Fax: 1-613-836-5089
sales@ozoptics.com

FIXED FILTERS

Features:

- Narrow Line Widths
- Rugged and Compact Size
- Removable Filter Holder Designs
- Wide Wavelength Range, 400 nm to 2100 nm
- Singlemode, Polarization Maintaining, and Multimode Fiber Versions
- Expanded Beam Technology
- LOW COST!

Applications:

- Dense Wavelength Division Multiplexing
- CATV, LAN and Telecommunications Use
- Test and Measurement

Product Description:

Fixed filters transmit or block specific wavelengths of light as they travel through the optical fiber. Light from the input fiber is first collimated and passed through the filter. The beam is then focused into the output fiber.

Filter linewidths are normally defined in terms of Full Width at Half Maximum (FWHM). The standard filters used have a smooth, rounded transmission spectrum that is the result of a single Fabry Perot type cavity. A Fabry Perot cavity is simply made up of two reflectors separated by a fixed spacer of some thickness. Other filter designs are available. For instance, flat top bandpass filters are made by stacking multiple cavities together. By increasing the number of cavities one can increase the roll-off slope therefore improving the out-of-band rejection level. Please contact OZ Optics for custom filter designs.

Fixed filters using singlemode, multimode or Polarization Maintaining (PM) fibers are offered. In general, OZ Optics uses polarization maintaining fibers based on the PANDA fiber structure when building polarization maintaining components and patchcords. However OZ Optics can construct devices using other PM fiber structures. We do carry some alternative fiber types in stock, so please contact our sales department for availability. If necessary, we are willing to use customer supplied fibers to build devices.

For tunable filters refer to our manual, motor driven, or digital tunable filter product lines.



Pigtail Style Fixed Filter



Miniature Pigtail Style Fixed Filter



Removable Filters

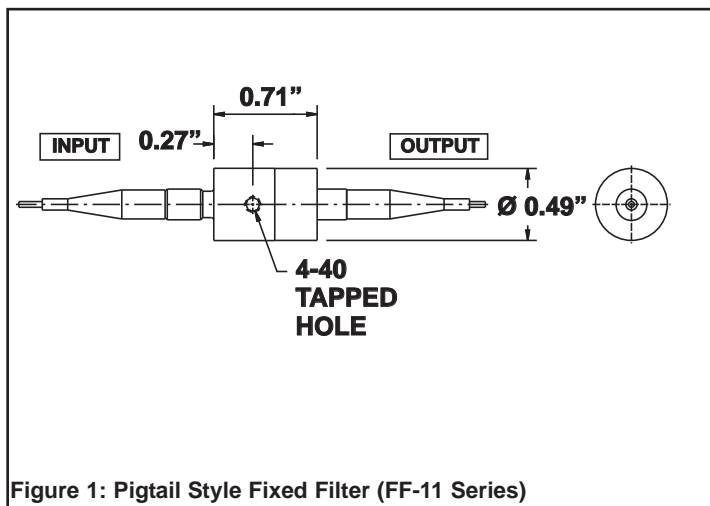

Figure 1: Pigtail Style Fixed Filter (FF-11 Series)

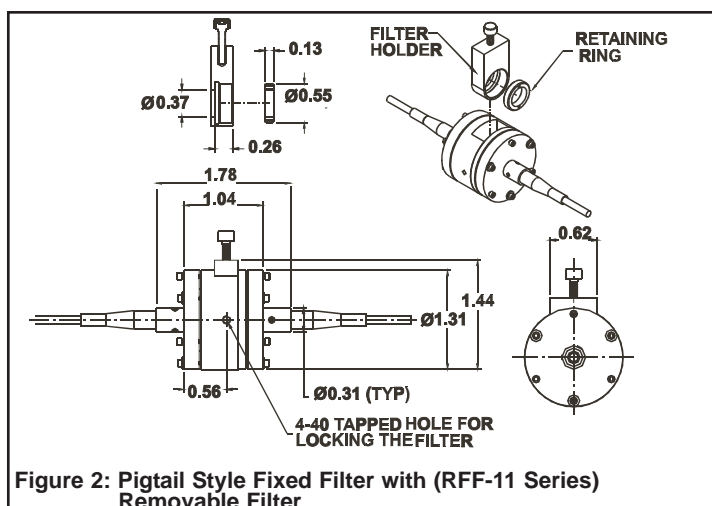

Figure 2: Pigtail Style Fixed Filter with (RFF-11 Series) Removable Filter

Ordering Information For Standard Parts:

Code		
51289	FF-11-1550-9/125-S-60-3A3A-1-1-3	Pigtail style fixed filter for 1550nm, with 1 meter long, 0.9mm OD jacketed 9/125 SM fiber pigtails, 60 dB return loss, FC/APC connectors and 3nm FWHM Fabry Perot filter
12178	FF-11-1550-8/125-P-60-3A3A-1-1-3	Pigtail style fixed filter for 1550nm, with 1 meter long, 0.9mm OD jacketed 8/125 PM fiber pigtails, 60 dB return loss, FC/APC connectors and 3nm FWHM Fabry Perot filter
51571	FF-21-1550-9/125-S-50-3A3A-1-1-100GHz	Miniature inline fixed filter (5.5mm OD package) for 1550.12 nm, 50dB return loss, with 1.0 meter long, 0.9mm OD jacketed 9/125 singlemode fiber pigtails terminated with angled FC/PC connectors and with a 100GHz flat top filter for 1550.12nm (Channel 34)
48164	FF-11-1550-8/125-P-60-3A3A-1-1-0.3	Pigtail style fixed filter for 1550nm, with 1 meter long, 1mm OD jacketed 8/125 PM fiber pigtails, 60 dB return loss, FC/APC connectors and 0.3nm FWHM Fabry Perot filter
10664	RFF-11-1550-9/125-S-50-3U3U-3-1-0.3	Pigtail style removable fixed filter for 1550nm, with 1 meter long, 3mm OD jacketed 9/125 SM fiber pigtails, 50 dB return loss, Ultra FC/PC connectors and 0.3nm FWHM Fabry Perot filter
9962	EASTMAN-02 & FOF-03	Replacement filter holder for removable fixed filter packages. Holds filters up to 12.7mm diameter by 3mm thick.

Standard Product Specifications:

Insertion Loss:	As low as 0.6dB
Line Width:	As low as 0.3nm
Available Wavelengths:	400-2100nm
Operating Temperature:	-20C to 65C
Pigtail Length:	Standard 1 meter on each end. Custom lengths available.
Filter Size:	Up to 12.7mm diameter by 3mm thick for removable filters.
PDL:	Typically less than 0.3dB. ¹
Power Handling:	Standard up to 200mW. 2W is available as an option.

¹ Does not include filter transmission characteristics

Ordering Examples For Standard Parts:

A customer has an application where ASE noise needs to be reduced for certain measurements at 1550nm and other measurements require no filtering. The part required for this application is a narrow line width removable fixed filter.

Bar Code	Part Number	Description
10664	RFF-11-1550-9/125-S-50-3U3U-3-1-0.3	Pigtail style removable fixed filter for 1550nm with 1 meter long, 3mm OD jacketed 9/125 SM fiber pigtails, 50dB return loss, ultra FC/PC connectors and 0.3nm FWHM Fabry Perot filter.

Ordering Information For Custom Parts:

OZ Optics welcomes the opportunity to provide custom designed products to meet your application needs. As with most manufacturers, customized products do take additional effort so please expect some differences in the pricing compared to our standard parts list. In particular, we will need additional time to prepare a comprehensive quotation, and lead times will be longer than normal. In most cases non-recurring engineering (NRE) charges, lot charges, and a 1 piece minimum order will be necessary. These points will be carefully explained in your quotation, so your decision will be as well informed as possible. We strongly recommend buying our standard products.

Questionnaire For Custom Parts:

- 1) What wavelength range are you interested in?
- 2) What line width do you require?
- 3) What type of fiber is being used? Singlemode, Multimode or PM?
- 4) Are you using a polarized or randomly polarized light source?
- 5) What return losses are acceptable in your system?
- 6) What connector type are you using?
- 7) Do you need a removable or permanently fixed filter?
- 8) How do you intend to use this product?

Fixed Filter

FF-A1-W-a/b-F-LB-XY-JD-L-LW

FF = Body Type:
FF for fixed filters
RFF for removable fixed filters

A = Filter Size
1 for standard size
2 for miniature pigtail size

W = Wavelength
1550 = Standard
other wavelengths available on request

a/b = Fiber core/cladding size, in μm
9/125 for 1300/1550nm Corning SMF-28 singlemode fiber
8/125 for 1550nm PANDA style PM fiber
7/125 for 1300nm PANDA style PM fiber
6/125 for 1060nm SM or PM fiber
other fibers available

F = M = Multimode
S = Singlemode
P = Polarization Maintaining

LW = Filter line width in nanometers. For flat top filters add "F" to the line width.
200GHz: 1.6nm line width for ITU DWDM Channel*
100GHz: 0.8nm line width for ITU DWDM Channel*

L = Fiber length, in meters

JD = Fiber jacket type:
1 = 900 μm OD Hytrel jacket
3 = 3 mm OD Kevlar reinforced PVC cable

X,Y = 3S=Super NTT-FC/PC
3U=Ultra NTT-FC/PC
3A=Angled NTT-FC/PC
8=AT&T-ST
SC=SC
SCA=Angled SC
LC=LC
LCA=Angled LC
MU=MU
X=No Connector

LB = Backreflection level:
40 or 60dB for singlemode or PM fibers only. (60dB for 1290 to 1620nm wavelength ranges only)
35dB for multimode fibers
50dB typical for DWDM channels

* Refer to the ITU G-692 frequency grid for a list of standard frequencies and matching wavelengths.

Ordering Examples for Custom Parts:

A 0.8nm line width filter with a flat top profile is needed for 1570.4nm, to transmit light at a specific channel in the ITU grid, while blocking spurious noise in a neighboring channel. Size is critical, so the customer needs the miniature style fixed filters. Return loss is not critical. The customer wants to use standard singlemode fiber pigtails, 1 mm jacketing, no connectors, each one meter long. Part number and description are as follows:

Part Number	Description
FF-21-1570.4-9/125-S-40-XX-1-1-0.8F	Pigtail style fixed filter for 1570.4nm, with 1 meter long, 0.9mm OD jacketed 9/125 SM fiber pigtails, 40 dB return loss, no connectors and 0.8nm FWHM flat top profile filter.

Frequently Asked Questions (FAQs):

Q: What is a Fabry-Perot filter? Are there other types available?

A: A Fabry-Perot filter has a smooth, rounded transmission spectrum that is the result of a single Fabry Perot type cavity. This shape is known as a Lorentz profile. A Fabry Perot cavity is simply made up of two reflectors separated by a fixed spacer of some thickness. By adjusting the spacer thickness one can adjust the pass bandwidth of the filter. Other shapes of filters are available. For instance, flat top bandpass filters are made by stacking multiple cavities together. By increasing the number of cavities one can increase the roll-off slope therefore improving the out-of-band rejection level. For more information on what custom filters are available please contact OZ Optics.

Q: How do you define your linewidths?

A: Standard filters are specified by their Full Width Half Maximum (FWHM). This is the transmitted linewidth at -3dB from the peak transmission. For custom filters linewidths such as the passband at -0.3dB and -25dB can be specified.

Q: Is the shape of the transmission curve affected by polarization?

A: No, OZ Optics tunable filters utilize an optical technique to control Polarization Dependent Losses (PDL). This design reduces PDL to minimal levels, while at the same time making the spectral response polarization insensitive.

Q: How well does the filter block unwanted wavelengths?

A: For standard single cavity Fabry Perot filters the typical linewidth at -20dB is roughly 10 times the FWHM linewidth. This type of filter is good for selecting specific channels in a DWDM system or cleaning up the ASE noise from a broadband source. The filter may transmit light at specific wavelengths significantly outside the operating wavelength range. For custom applications requiring different out-of-band isolation please contact OZ Optics.

Q: What linewidth do I need in a 200GHz DWDM system? 100GHz? 50GHz?

A: Typical linewidths associated with these frequencies are 1.6, 0.8 and 0.4nm respectively. This ultimately depends on the channel width and isolation levels required for the system in question. OZ Optics can work with you to build the filter that best suits your requirements.

Q: Can I order a tunable (manual or motorized) filter from OZ Optics?

A: Yes. OZ Optics offers a broad line of manual or motorized tunable filters. For more details refer to the following product family: *Digital Tunable Filter* (http://www.ozoptics.com/ALLNEW_PDF/DTS0006.pdf), *Motor Driven Tunable Filters* (http://www.ozoptics.com/ALLNEW_PDF/DTS0054.pdf) or *Manually Tunable Filters* (http://www.ozoptics.com/ALLNEW_PDF/DTS0051.pdf).

Application Notes:

In many fiber-optic applications we need to use light with a specific frequency or wavelength λ . Although a laser may be an excellent source of monochromatic radiation, we might need a source of light providing controlled, variable wavelength. We could use a white light source, collimated into a beam through a glass prism for spectral dispersion. Then we could move a slit across the rainbow output, systematically tuning to the required wavelength. By contrast, bandpass filters provide an effective modern means of transmitting a well-defined band of light while blocking unwanted wavelengths emitting from a broadband source.

Types of filters (transmission versus wavelength):

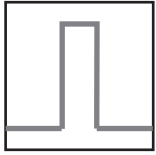

bandpass

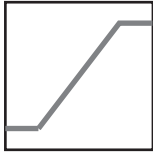

longpass



neutral density

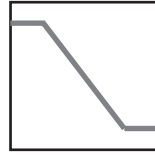

shortpass

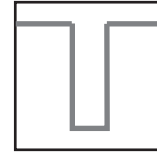

notch

The simplest bandpass filter is made up of a single cavity filter with an AR coating on the backside of the substrate. More complex filters can have multiple cavities. Vapor deposition techniques are typically used to control the composition and thickness of the layers and films, thus controlling both the bandwidth and the center wavelength of the filter.

The typical output wavelength distribution is demonstrated in (Figure 3).

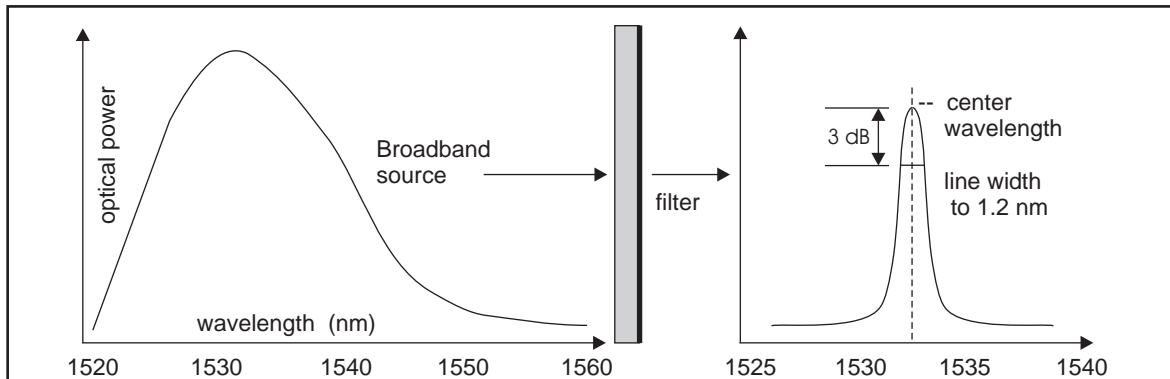

Figure 3: Use of a broadband source and a fixed filter to create a narrow-band signal. First, the bandwidth of the filter is chosen appropriate to the source. The output light is attenuated but has a narrow spectral width. The width is measured at 3 dB below the peak.

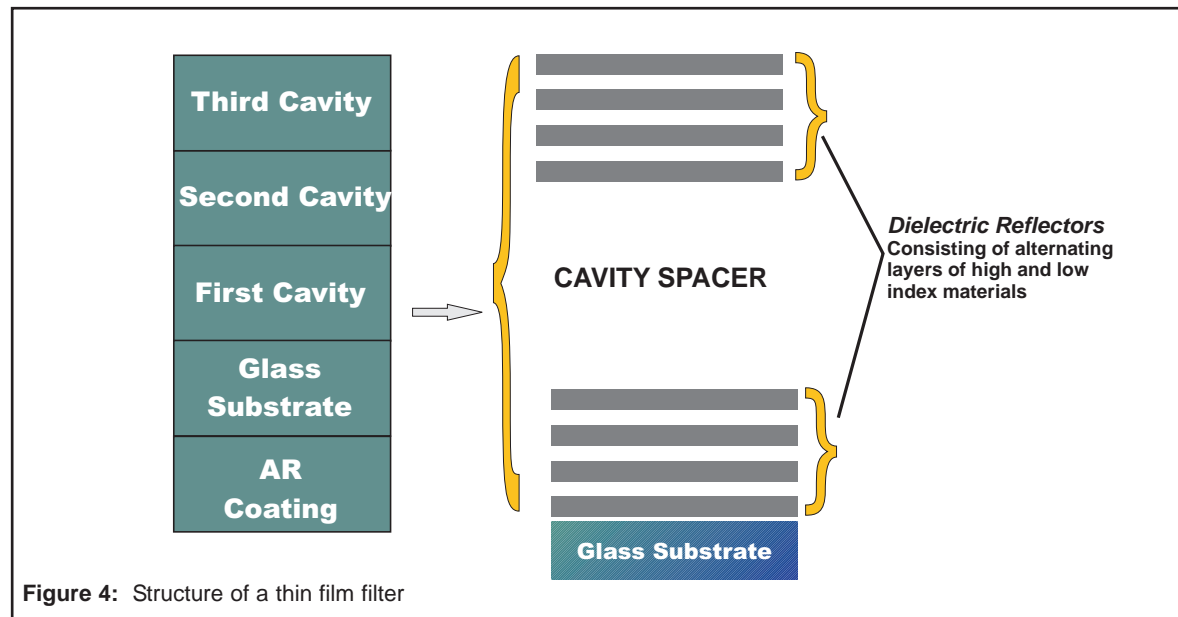

Figure 4: Structure of a thin film filter

Figure 4 is a sketch showing the structure of a thin film filter. It is made of layers of different materials with alternating high and low index of refraction. The optical interface between the layers gives rise to the bandpass filter functionality. The minimal structure that is required to give rise to the bandpass filter functionality is referred to as a single cavity, which is the building block for most filter designs.