



ozOptics
shop.ozoptics.com
www.ozoptics.com

219 Westbrook Road
Ottawa, ON, Canada, K0A 1L0

Toll-free: 1-800-361-5415
Telephone: 1-613-831-0981
Fax: 1-613-836-5089
sales@ozoptics.com



HIGH POWER FREE SPACE AND FIBER PIGTAILED ISOLATORS

Features:

- New! Reduced size and cost versions
- Reliable high power handling: As much as 80 Watts
- High Isolation, up to 50dB isolation possible from a single stage
- Low Insertion losses, less than 0.5dB for fiber to free space
- Low polarization dependent losses, as low as 0.2dB
- Wide Spectral Range: 60nm operating wavelength range
- Large Clear Aperture: Versions can accommodate beams up to 1.2mm in diameter
- Excellent Beam Quality: Typically M^2 factor of 1.2 with standard fiber
- Easily mountable options for fiber collimators and beam expanders
- Superior design with removable protective windows
- Pigtail or adjustable focus receptacle style collimators/focusers for fiber to free space versions
- RoHS compliant
- Custom smaller packages can be made for OEM applications. Contact factory for more details

Applications:

Protection of high power lasers from reflections during:

- Laser marking and engraving
- Laser cutting and etching of metal surfaces with high reflectance such as Aluminum, Copper, Gold or Silver
- Micro Machining and Trimming

Introduction:

Isolators are optical devices that allow light to be transmitted in one direction only. They are most often used to prevent any reflected light from entering the source, thus preventing any feedback problems, such as frequency instability, relaxation oscillations, amplified stimulated emissions, or optical damage from occurring.

With the recent dramatic increase in laser output powers, especially in the 1030 to 1090nm wavelength range, the need to prevent the negative effects of optical feedback into lasers has become critical. To meet this demand OZ Optics has developed a line of high power handling polarization independent isolators, capable of peak isolation levels of 30 to 50dB for 1030 to 1090nm, depending on the input beam size. The isolators are offered with fiber pigtailed collimators on the input beam, with typical beam diameters of 0.4mm to 1.1mm.

Product Description:

OZ Optics uses a patented tilt alignment technique to manufacture isolators with fiber pigtails. Light from an optical fiber is first collimated then transmitted through the isolator. If desired, a similar fiber pigtailed collimator can be mounted on the output end of the isolator for a fiber pigtailed isolator. The fibers can be standard single mode fibers or Large Mode Area (LMA) fibers. LMA fibers are used to reduce the optical power density in the fiber core and therefore allow guidance of larger input power levels while still achieving near-gaussian output beam quality.

This patented tilt alignment technique allows OZ Optics to offer compact pigtailed devices. The isolators come with built-in windows to prevent dust contamination of internal isolator optics. These protection windows are easily removed and replaced by the user.

OZ Optics also offers receptacle style fiber to free-space isolators (see figure 4) where customers can connect a high power patchcord terminated with an adjustable FC connector (see figure 5). This option gives the user extra flexibility in the control of beam size propagating through the isolator, and allows the user to change the fiber if desired.



Compact, High Power Isolator: FOPI-10A



Fiber Pigtailed Collimator to Free Space
1064nm Isolator: FOPI-10



1W Fiber-to-Fiber Isolator: FOPI-11A



High Power Free Space Isolator: FOPI-00

Polarization insensitive isolators use birefringent crystals to separate the input beam into two orthogonal polarizations, transmit them through the Faraday crystal and then recombine them to produce an output beam.

For maximum transmission, low absorption and high isolation, careful alignment of the internal components with respect to the propagating optical beam is needed. We offer three versions. The key specifications for these three versions are summarized in Tables 1–3.

Fiber Optic Isolator Product Specifications:

Table 1: Compact Fiber-to-Free-Space Isolator Specifications (FOI-10A, FOPI-10A)

Parameter	Min.	Typ.	Max.	Notes
Operating wavelength (nm)	1064 ± 15			Center wavelength ¹
Beam Size (mm)	0.4mm for up to 20W. 0.7mm for 50W			Without Beam Expander
	6–8			With Beam Expander
Operating temperature (°C)	10–50			At 1064nm
Power Handling (W)			50	At 1064nm, 23°C
Insertion Loss (dB)		0.3	0.5	At 1064nm, 23°C
Isolation (dB)	30	35		At 1064nm, 23°C
Isolation over temperature range (dB)	25			At 1064nm
Return Loss (dB)	50			
Polarization Dependent Loss (dB)			0.15	
Package Size ² (mm)	42x42x90			Reference Figure 1

¹ Other wavelengths available on request. Contact OZ for detailed specifications.

² Due to ongoing design improvements, a smaller package size may be available.

Table 2: 1W Fiber-to-Fiber Isolator Specifications (FOPI-11A, FOI-11A)

Parameter	Min.	Typ.	Max.	Notes
Operating wavelength (nm)	1064 ± 5			Center wavelength ³
Operating temperature (°C)	10–50			At 1064nm
Power Handling (W)			1	At 1064nm, 23°C
Insertion Loss (dB)			2	At 1064nm, 23°C
Isolation (dB)	30			At 1064nm, 23°C
Isolation over temperature range (dB)	25			At 1064nm
Return Loss (dB)	50			
Polarization Dependent Loss (dB)			0.2	Polarization independent isolator only
Package Size (mm)	12x12x31			Reference Figure 5

³ Other wavelengths available on request. Contact OZ for detailed specifications.

Table 3: High Power Free Space Isolator Specifications⁴ (FOI-00, FOPI-00, FOI-10, FOPI-10)

Parameter	Min.	Typ.	Max.	Condition
Operating wavelength (nm)	1040		1090	At 25°C
Operating temperature (°C)	10–50			At 1064nm
Power handling (W)	30	50	80	At 1064nm, 25°C
Insertion loss (dB)		0.3	0.5	At 1064nm, 25°C
Isolation (dB)	35	40		At 1064nm, 25°C
Isolation over temperature range (dB)	21			At 1064nm over 10–50°C
PDL (dB)		0.1	0.2	Polarization independent only
Nominal beam diameter ⁵ (mm)	0.8	1.0	1.2	
Beam M ² factor		1.1	1.2	With single mode input fiber
Beam divergence (mrad)			1	Full angle, using singlemode input fiber
Pointing accuracy (mrad)			1	With singlemode input fiber
Beam expander magnification	Various magnifications available upon request			Depending on type of input fiber used
Package size ⁶ (mm)	48x48x133			Reference Figure 4

⁴ Other wavelengths available on request. Contact OZ Optics for detailed specifications.

⁵ Other beam diameters available on request.

⁶ Due to ongoing design improvements, the package size is subject to change. Please contact OZ Optics for confirmation.

OZ Optics can provide free space isolators with options to allow the customer to mount their own fiber pigtailed collimator or beam expander. The OZ Optics tilt adjustment technique gives customers the ability to perform the optical alignment themselves.

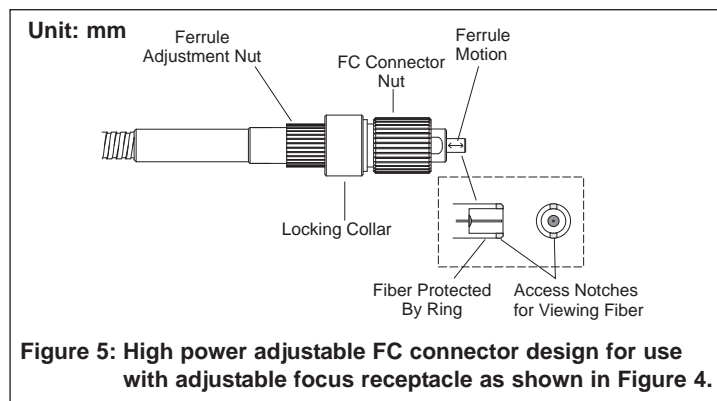
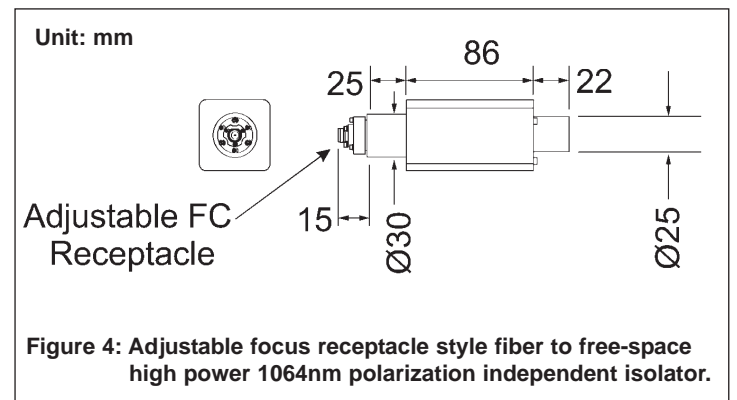
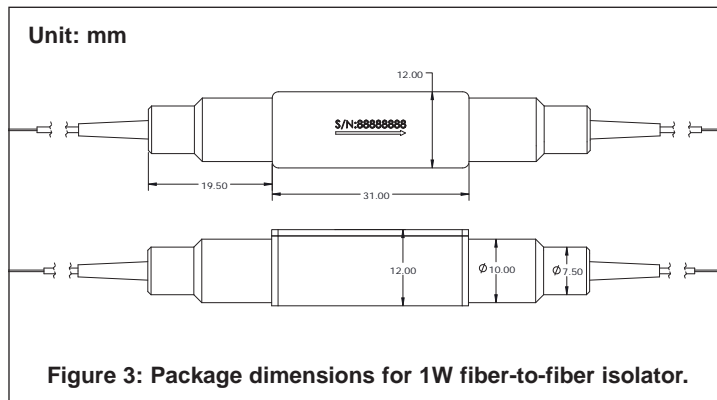
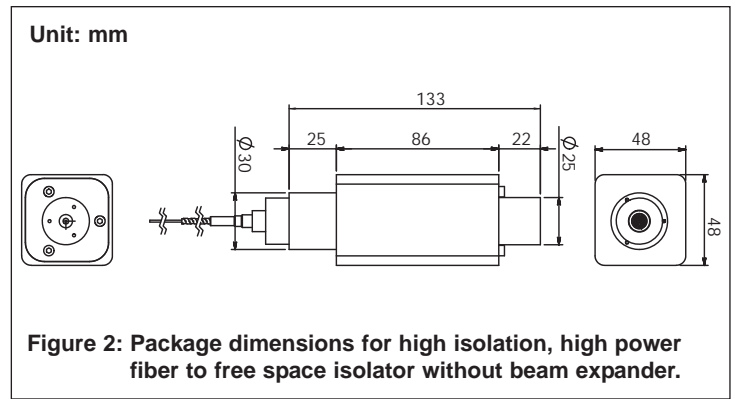
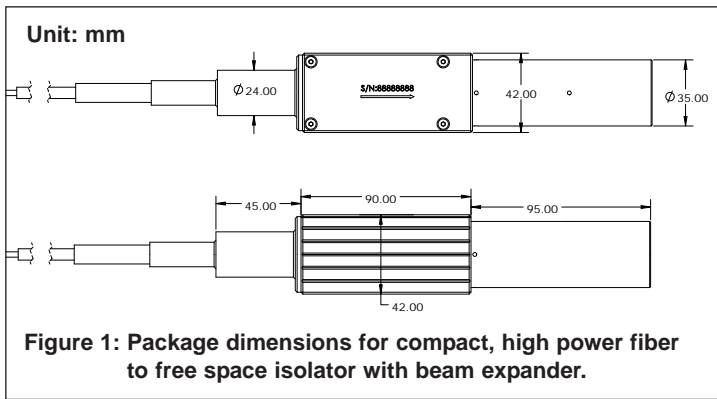

Ordering Information:

Questionnaire

Please answer the following questions, so we can quote you the best isolator for your application. For custom parts, please contact OZ Optics.

1. What is your input power level? Is it CW or pulsed? If it is pulsed, what are the peak power, repetition rate, and pulse duration?
2. What is the center wavelength of your source?
3. Do you need a free-space isolator, a fiber-to-free-space isolator or a fiber pigtailed isolator?
4. Do you need 40dB or 35dB isolation?
5. If free-space type, what is your input beam diameter?
6. If the fiber-to-free-space type, what type of input fiber do you require: Standard singlemode, polarization maintaining, or LMA fiber. If LMA, please supply fiber specifications -fiber manufacturer's datasheet if possible, core/cladding size, and core & cladding numerical aperture value at the least.
7. For fiber pigtail, do you need 3mm OD, 5mm OD, or heavier armor cabled fiber?
8. Do you need a beam expander assembly at the output? If so, what is the required collimated beam diameter?
9. Do you need a connector on the free end of the fiber pigtailed collimator? Please note that in general power handling capability of connectors may not be high as the isolator. For example, we recommend that connectors are only used to facilitate testing of device at low power levels and that fiber is directly fusion spliced to the fiber laser source.

Description

Part Number

Free Space Isolator:

***F*OPI-00-*W*-1.5-40-*HP*(*Y*)**

Isolator Type

FOPI for Polarization Independent Isolator
FOI for Polarization Dependent Isolator

W= Wavelength in nm
1064nm standard
1030-1090nm available

CA = Clear aperture (mm)
1.5mm standard

Y = CW Power handling in Watts
1-50W available

I = Peak isolation in dB
40dB

Description

Part Number

Fiber Pigtailed Collimator ***F*OPI-10(*A*)-*W*-*a/b*-*F*-*BD*-*f*-*BL*-*X*-*JD*-*L*-*I*-*HP*(*Y*)-*BE*(*M*)**
to Free Space Isolator:

Isolator Type

FOPI for Polarization Independent Isolator
FOI for Polarization Dependent Isolator

A = Body type A: Compact 42x42 housing
blank: 48x48 housing

W= Wavelength in nm
1064nm standard
1030-1090nm available

a/b = Fiber core and cladding diameters, in microns: (Example: 6/125 for standard 1064 nm singlemode or PM fiber)

F = Fiber Type: S = Singlemode
P = Polarization maintaining
LMA = Large Mode Area
PLMA = PM Large Mode Area

BD = Beam Diameter, in mm
Typically 0.4mm for compact housing
1mm for standard housing

f = Lens focal length and type: (OZ Optics will choose lens type appropriate for fiber type, power level and beam size)

BL = Backreflection level:
50, 60 dB for 1064 nm

BE = Beam Expander
M = Magnification
M = 1 is no beam expander

Y = CW Power handling in Watts
1, 2, 5, 10, 20, or 50

I = Peak isolation in dB
35dB: 42x42mm housing
40dB: 48x48mm housing

L = Fiber length in meters

JD = Jacket Diameter
3AS = 3mm OD stainless steel armored
5AS = 5mm OD stainless steel armored
See table 7 of the *Standard Tables* for other options.
http://www.ozoptics.com/ALLNEW_PDF/DTS0079.pdf

X = Connector code:
X = No connector
3S = Super NTT-FC/PC
3A = Angled NTT-FC/PC
See table 6 of the OZ *Standard Tables* data sheet for information on connectors.
http://www.ozoptics.com/ALLNEW_PDF/DTS0079.pdf

Note: In some cases standard connectors may not work for the desired power handling. Connectors are offered for testing at low powers only. For use at high power levels, please cut off the connector and fusion splice to the laser source.

Description

Part Number

Fiber to Fiber Pigtailed Isolator:

FOPI-11(A)-11-W-a/b-F-BL-XY-JD-L-I-HP(Y)

Isolator Type

FOPI for Polarization Independent Isolator
FOI for Polarization Dependent Isolator

A = Body type: A = 12x12mm housing
Blank = 48x48mm housing

W = Wavelength in nm
1064nm standard
1030–1090nm available

a/b = Fiber core and cladding diameters, in microns: (Example: 6/125 for standard 1064 nm singlemode or PM fiber)

F = Fiber Type: S = Singlemode
P = Polarization maintaining
LMA = Large Mode Area
PLMA = PM Large Mode Area

BL = Backreflection level:
50, 60 dB for 1064 nm

Y = CW Power handling in Watts
Note: >2Watts only available for 48x48mm housing.

I = Peak isolation in dB
30dB: 12x12mm
40dB: 48x48mm

L = Fiber length in meters

JD = Jacket Diameter
3AS = 3mm OD stainless steel armored
5AS = 5mm OD stainless steel armored
See table 7 of the *Standard Tables* for other options.
http://www.ozoptics.com/ALLNEW_PDF/DTS0079.pdf

X,Y = Connector code:
X = No connector
3S = Super NTT-FC/PC
3A = Angled NTT-FC/PC

See table 6 of the OZ *Standard Tables* data sheet for information on connectors.
http://www.ozoptics.com/ALLNEW_PDF/DTS0079.pdf

Note: In some cases standard connectors may not work for the desired power handling. Connectors are offered for testing at low powers only. For use at high power levels, please cut off the connector and fusion splice to the laser source.

Part Number Example For Fiber Pigtailed Collimator to Free-Space Isolator:

Part Number: FOPI-10A-1064-35/250-LMA-0.4-4.2CL-50-X-3AS-1-35-HP20-BE15

Description:

Compact Fiber to Free-space beam Polarization Independent isolator for 1064nm with 20 Watt power handling. Input side consists of a pigtail style collimator for 1064nm with 1 meter long, 3mm OD stainless steel cabled 35/250µm LMA passive singlemode fiber, with 50dB return loss. The output beam diameter will be about 0.4mm, expanded to 6mm with a 15X beam expander. The isolator will transmit light entering the fiber and the collimator assembly, and block light entering from the free-space beam output side. The peak isolation level is approximately 35dB. HP20: High power application for up to 20 Watt average power handling (1.5mJ@100ns, 20kW peak power).