

RECOMMENDED PANEL HOLE

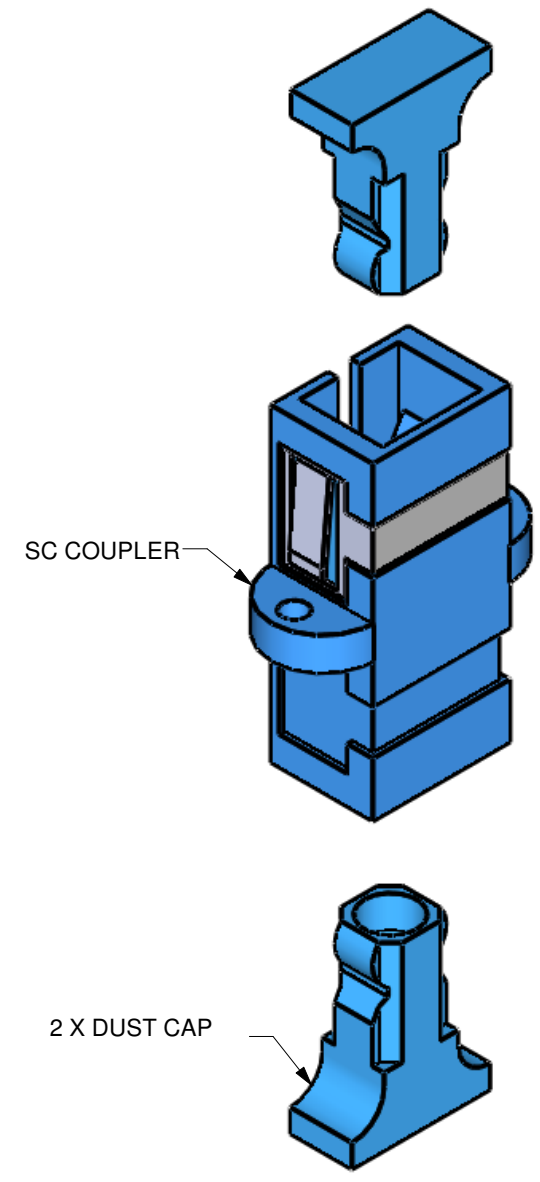
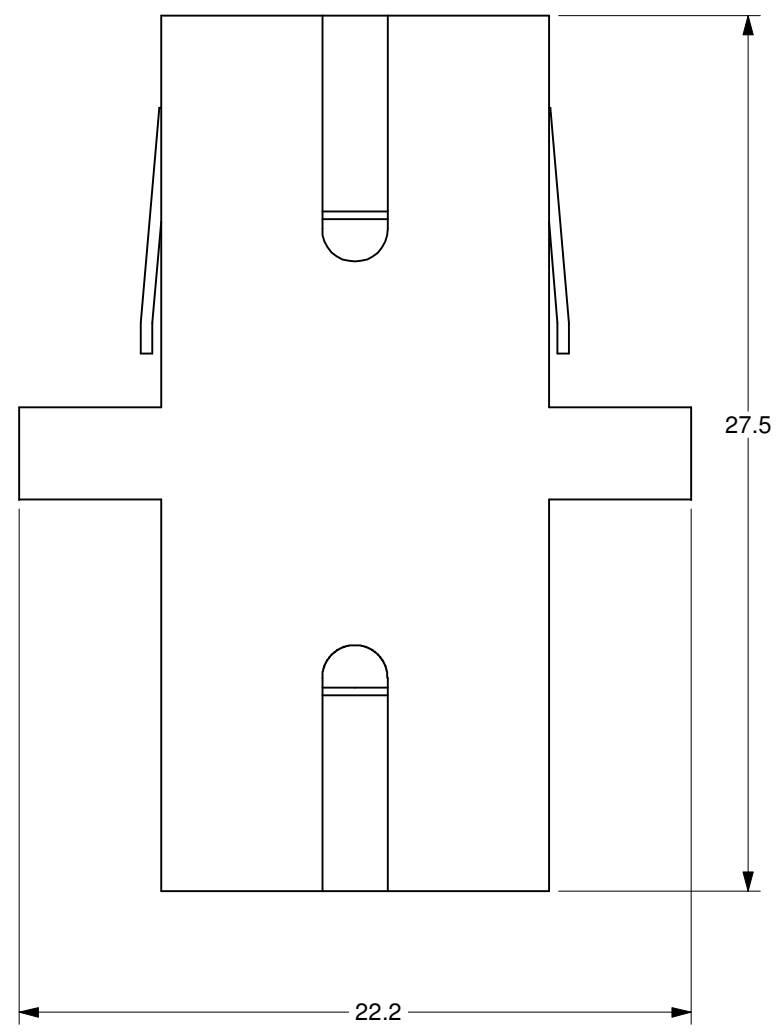

DIMENSIONS ARE IN MILLIMETERS.

DRAWN BY: K. SINA	DATE: 12/18/13	UNLESS NOTED OTHERWISE, DIMENSIONS ARE IN MILLIMETERS, INCHES ARE IN SQUARE BRACKETS, AND TOLERANCES APPLY AS SHOWN BELOW.			219 WESTBROOK ROAD OTTAWA, ONTARIO CANADA K0A 1L0		PART BARCODE #:
CHECKED BY:	DATE:				32619		
M/S CHECKED BY:	DATE:	INCHES BASIC DIMENSION .XX .XXX BELOW 4 ±.01 ±.005 OVER 4 ±.02 ±.01		DESC. SC/SC Single Mating Sleeve		PART NO. BULK-0SC-SP	REV N/A
APVD BY:	DATE:	MILLIMETERS BASIC DIMENSION .X .XX BELOW 101.6 ±.25 ±.10 OVER 101.6 ±.50 ±.20		SIZE: B DWG.# 3000-0268 SHEET 1 OF 1 SCALE: 4:1			
PROJECTION:		ANGULAR DIMENSIONS BASIC DIMENSION X X.X ALL ANGLES ±2.5° ±0.5°		SURFACE FINISH MILLED 125u PROFILED 63u			
CONFIDENTIAL THIS PRINT IS THE EXCLUSIVE PROPERTY OF OZ OPTICS AND MUST BE RETURNED UPON REQUEST. UNAUTHORIZED USE, MANUFACTURE OR REPRODUCTION IN WHOLE OR IN PART IS PROHIBITED.							