

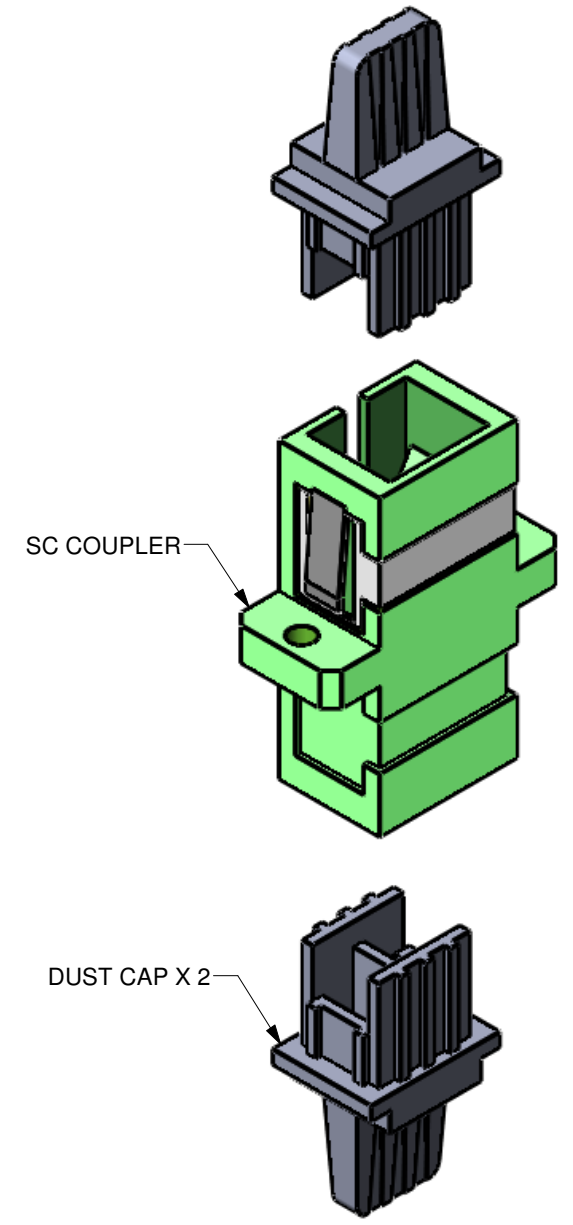

RECOMMENDED PANEL OPENING



SC COUPLER

DUST CAP X 2

DIMENSIONS ARE IN MILLIMETERS.

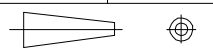
| | | | | | | |
|---|---|--|--|---|---|--------------------|
| DRAWN BY: S. BOUJLOV | DATE: 2/04/14 | UNLESS NOTED OTHERWISE, DIMENSIONS ARE IN MILLIMETERS, INCHES ARE IN SQUARE BRACKETS, AND TOLERANCES APPLY AS SHOWN BELOW. | |  | 219 WESTBROOK ROAD OTTAWA, ONTARIO CANADA K0A 1L0 | PART BARCODE #: |
| CHECKED BY: | DATE: | INCHES BASIC DIMENSION .XX .XXX BELOW 4 ±.01 ±.005 OVER 4 ±.02 ±.01 | | | | 5217 |
| M/S CHECKED BY: | DATE: | MILLIMETERS BASIC DIMENSION .X .XX BELOW 101.6 ±.25 ±.10 OVER 101.6 ±.50 ±.20 | | DESC: | Bulkhead receptacle for SC/APC connectors | |
| APVD BY: | DATE: | ANGULAR DIMENSIONS BASIC DIMENSION X X.X ALL ANGLES ±2.5° ±0.5° | | PART NO.: | BULK-0SC-APC | |
| PROJECTION: |  | SURFACE FINISH MILLED 125u PROFILED 63u | | SIZE: | B | SCALE: 2:1 |
| CONFIDENTIAL THIS PRINT IS THE EXCLUSIVE PROPERTY OF OZ OPTICS AND MUST BE RETURNED UPON REQUEST. UNAUTHORIZED USE, MANUFACTURE OR REPRODUCTION IN WHOLE OR IN PART IS PROHIBITED. | | | | DWG.# | 3000-0263 | SHEET 1 OF 1 |