



# OZ Optics

shop.ozoptics.com  
www.ozoptics.com

219 Westbrook Road  
Ottawa, ON, Canada, K0A 1L0

Toll free: 1-800-361-5415  
Telephone: 1-613-831-0981  
Fax: 1-613-836-5089  
sales@ozoptics.com

# Fiber Optic Distributed Strain and Temperature Sensors (DSTS)

## BOTDR Module

For more information about our strain and temperature sensor system and related products, please visit [www.ozoptics.com](http://www.ozoptics.com)

Photo: 3U chassis and laptop computer shown.

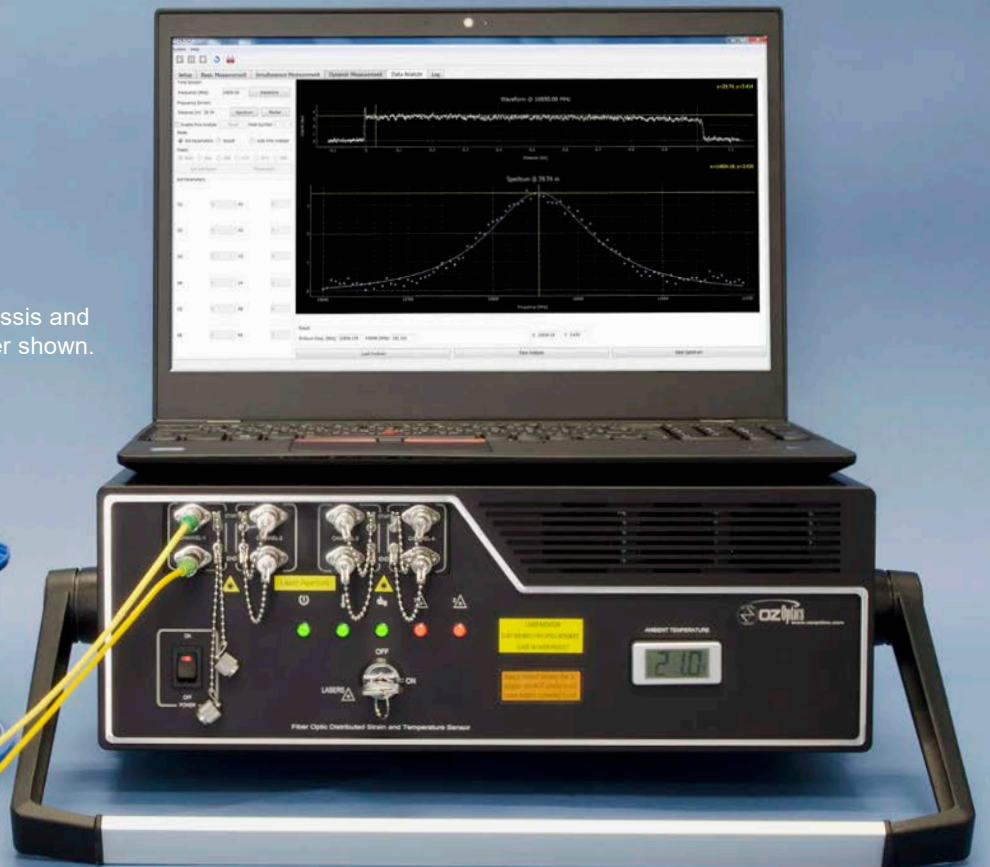
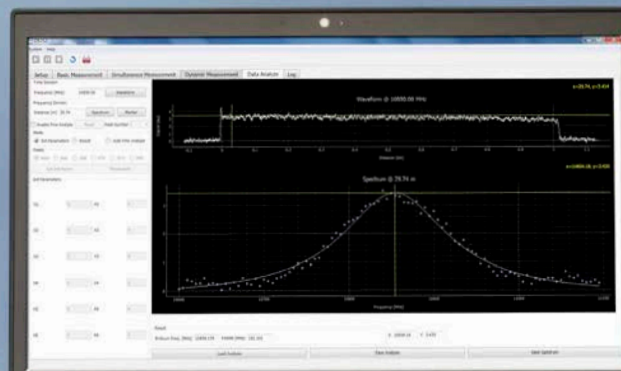

### Features

- Single end measurement
- Uses low-cost telecom single mode fiber
- Fine spatial resolution and long range
- Multiple channel monitoring available

### Performance at a glance

- As low as 1 m spatial resolution
- 70 km maximum sensing range
- $\pm 0.8^\circ\text{C} / 16\mu\epsilon$  accuracy ( $\sigma$ )

### Description

OZ Optics' ForeSight™ family of fiber optic Brillouin distributed strain and temperature sensors (DSTS) are sophisticated optical sensor systems employing Brillouin scattering. Distributed sensing provides a direct method of measuring the changes in strain and temperature along the entire length of an optical fiber. A new BOTDR (Brillouin Optical Time Domain Reflectometer) module based on spontaneous Brillouin scattering is now available. Even if there is a break somewhere on the fiber, this unit can still measure strain / temperature up to the point of the break.

## Oil and Gas applications



### Oil and Gas Pipeline Monitoring

- Pipeline leakage monitoring
- Up to 70 km sensing range per channel
- High spatial resolution supports localized measurement with long sensing range



### Oil and Gas Well Monitoring

- Well integrity management
- Temperature, strain and pressure monitoring with proper sensing cable and installation
- Not sensitive to hydrogen which may change the attenuation of the fiber



### Refinery Efficiency Sensing

- Improve the efficiency of the refinery per distributed temperature profile
- Reduce downtime while ensuring safety levels
- Uses low cost telecom single mode fiber cable

## Civil Engineering applications



### Dam Monitoring

- Dam internal temperature monitoring
- Crack / sediment / deformation / seepage monitoring
- Up to 70 km sensing range per channel



### Structural Health Monitoring (SHM)

- Sediment monitoring
- Strain and crack monitoring
- Up to 70 km sensing range per channel
- High spatial resolution supports localized measurement with long range object



**Civil Engineering applications** *continued*



**Geohazard Monitoring**

- Landslide, subsidence and deformation of levee / ground / highway monitoring
- Can monitor trends in ground movement
- Up to 70 km sensing range per channel



**Highway Safety Monitoring**

- Internal temperature / strain monitoring with proper sensing cable and installation
- Highway subsidence monitoring
- Distributed temperature / strain data along the fiber length up to 70 km

**Utility and cable applications**



**Overhead Power Line Monitoring**

- Icing and broken wires can be detected
- Up to 70 km sensing range per channel
- No additional component is required along power line route
- Easy deployment



**Submarine Cable Monitoring**

- Ongoing quality / status monitoring throughout the life of the cable
- Only requires one fiber
- No additional component is required along the route

**Cryostat applications**



**Quality Inspection of Fiber Optic Cable**

- More sensitive to strain than OTDR
- High level quality control based on high level technology
- Can monitor the quality of power cable / OPGW with optical fiber unit



**Cryostat Temperature Sensing**

- Able to measure temperatures as low as 25 K
- May use low cost telecom single mode fiber
- Up to 70 km sensing range per channel

## Specifications

		Model	Foresight™ Series BOTDR module
Performance	Number of Channels		2 to 25 <sup>1</sup>
	Sensor Configuration		Single end
	Sensing Range		70 km
	Spatial Resolution		1 m to 80 m
	Spatial Step		as low as 5 cm
	Dynamic Range		>15 dB
	Temperature Range		-100°C to +500°C <sup>2</sup> (depending on cable material)
	Temperature Resolution		0.005°C <sup>3</sup>
	Temperature Accuracy (2σ)		± 0.8°C <sup>4</sup>
	Strain Range		-0.2% to +1% <sup>2</sup> (depending on cable material)
	Strain Resolution		0.1µε <sup>3</sup>
	Strain Accuracy (2σ)		± 16µε <sup>4</sup>
	Measured Variables		Strain, Temperature, Brillouin spectrum
General	Communication & Connections		Ethernet port, USB
	Output Signals		Software alarms via TCP/IP, SPST, SSR relays (optional)
	Data Storage		Internal hard disc (128GB or more)
	Data Format		Database, text files, MS Excel, bitmap plot
	Optical Connections		FC/APC <sup>5</sup>
	Laser Wavelength		1550 nm band
	Operating Temperature		0°C to 40°C, <85% RH, non-condensing
	Power Supply		115 or 230 VAC; 50–60Hz; max 300W
	Dimensions (L x W x H)	3U Chassis	390 mm x 344 mm x 133 mm (not including computer) <sup>6</sup>
	Weight	3U Chassis	<12 kg (not including computer)
Features	Measurement Modes		Manual, remote or automatic unattended measurements
	Data Analysis		Measurement analysis, multiple trace comparison with respect to selectable baseline, measurement trends, graphical zoom
	Alarms & Warnings		Automatic alarm triggering, configurable alarm settings (gradient, threshold, etc.)
	Remote Operation		Remote control, configuration and maintenance via TCP/IP
	Watch Dog		Long term operation 24/7 guaranteed by automatic recovery and continuous self diagnostics

<sup>1</sup> 2 channels or 4 channels are provided within the sensor unit. Additional channels can be added by using an external optical switch.

<sup>2</sup> -270°C to 1500°C and -3% to +3% is optional.

<sup>3</sup> This value is estimated/calculated from the uncertainty of laser beat frequency (5 kHz), and temperature and strain coefficients of fibers.

<sup>4</sup> Measurement condition: 1 km SM fibers with unstrained condition at pulse width of 10 ns, average time of 60000, frequency sweep span of 300 MHz with frequency step of 5 MHz, standard deviation (2σ) of 100 consecutive data on temperature/strain distribution waveform.

<sup>5</sup> Adaptors and patch cords are available for mating with other types of optical connectors.

<sup>6</sup> Dimensions do not include carrying handle. Air vents on sides of unit must not be obstructed.

Typical measurement results table

		Spatial Resolution						
		1 m	2.5 m	4 m	10 m	25 m	35 m	40 m
Fiber Length	1 km	± 0.8°C / ± 16µε						
	2 km	± 1.2°C / ± 24µε						
	5 km	± 1.5°C / ± 30µε						
	10 km		± 1.5°C / ± 30µε					
	20 km			± 1°C / ± 20µε				
	30 km				± 1.5°C / ± 30µε			
	40 km				± 1.5°C / ± 30µε			
	50 km					± 1.75°C / ± 35µε		
	60 km						± 1.25°C / ± 25µε	
	70 km							± 2°C / ± 40µε

Results listed above are based on 100 continuous measurements using a single mode sensing fiber with zero strain. Averaging a greater number of scans can provide better precision but it will require a longer measurement time.

## Optional Accessories

Bar Code	Part Number	Description
74023	DSTS-TRAVEL-CASE-3U	Plastic travel case for 2U or 3U DSTS unit, with extendable pull handle and wheels. Designed for checking on airplane. Approximate dimensions: 23.75 (H) x 22.5 (W) x 15 (D). {60.3 cm x 57.2 cm x 38.1 cm}.
65518	FIBER MICROSCOPE HANDHELD	Handheld Video Microscope kit for Fiber Optic Connector Inspection. The kit includes an LCD display with video probe. An AC power adapter with battery charger and a rechargeable battery pack is included. Several common adaptor types come with the unit, including an SC/FC PC female adaptor and an LC/PC female adaptor.
48980	CI-1100-A2-PT2-FS/APC/F	Tip for SC and FC APC type female (in receptacle) connector for CI-1100-A2 handheld microscope.
36939	HUXCLEANER-2.5	Receptacle fiber cleaner for FC, SC and ST type.
5336	Fiber-Connector-Cleaner-SA	Disposable Cletop reel type A optical fiber connector cleaner.
8122	SMJ-3A3A-1300/1550-9/125-3-1	1 meter long, 3 mm OD jacketed, 1300/1550 nm 9/125 $\mu$ Corning SMF 28e fiber patchcord, terminated with angled FC/APC connectors on both ends.
11	PMPC-03	Flanged sleeve thru connector for polarization maintaining FC/PC connectors. Keyway width is 2.03/2.07 mm wide for 2.00 mm wide (Type R) key connectors.
19711	AA-200-11-9/125-3A3A	Universal connector with a male angle FC/APC connector at the input and a female angle FC/APC receptacle at the output end for SM 9/125 applications.
58975	DSTS-3U-19IN-RACK-MOUNT-KIT	Brackets with handles & hardware to convert 3U DSTS to 19" rack mountable version.
77982	FSP-100-S/M	Fiber fusion splicer for singlemode and multimode fiber, featuring fiber core alignment and automatic fiber identification (singlemode vs multimode) for optimum splice loss. Suitable for bare fibers, patch cords, drop cables etc. A fiber cleaver and fiber stripper is included with the unit as a kit.
77984	FSP-100-CLV	Precision fiber cleaver for fusion splicing, with automatic blade rotation for maximum lifetime.

## Ordering Information

Part Number Description: **DSTS-CT CO I-SR-MSR-AS-BOTDR-X-CH**

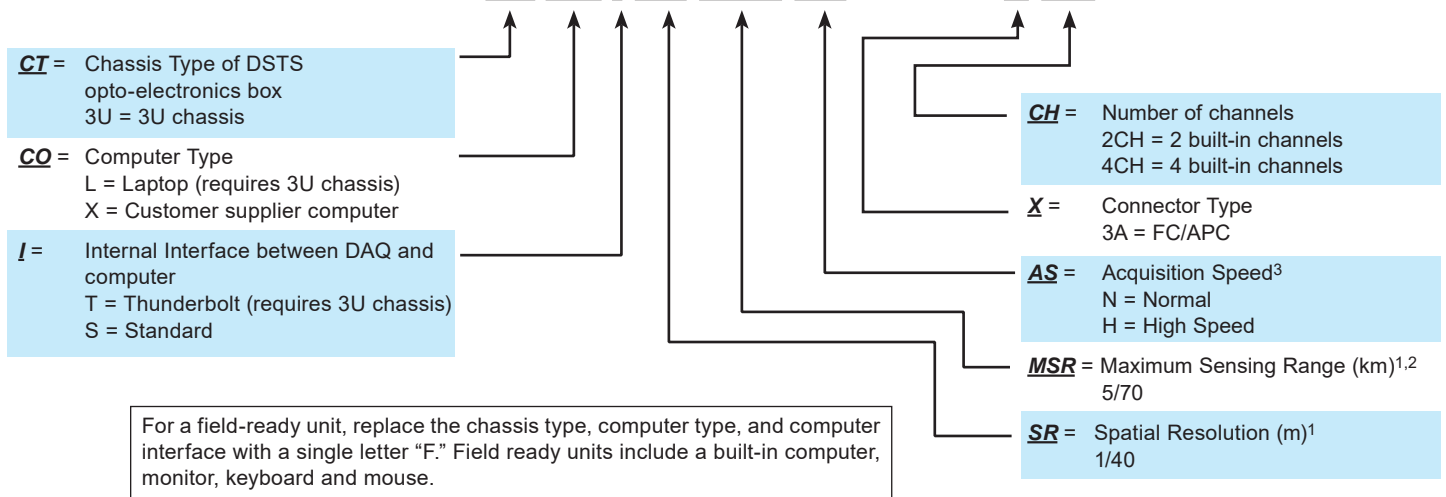

### Notes:

- The spatial resolution indicates the best resolution at the maximum sensing range. Two numbers will be listed indicating the resolutions and maximum sensing range for each operating mode. For example, suppose the DSTS unit needs to achieve 1 meter resolution over a 5 km range, and 40 meter resolution over a 70 km range. The part number will specify the spatial resolution (SR) as 1/40, and maximum sensing range (MSR) as 5/70. These are the default values. Contact OZ Optics if other values are required.
- Maximum sensing range is 70 km. Alternately, if the 1 m spatial resolution is chosen, a maximum sensing range of 5 km is displayed for that resolution. Maximum sensing range is described as 5/70.
- The acquisition speed is described as normal or high speed. N and H are used respectively. The high-speed version is typically at least a factor of two faster than the normal-speed version during the acquisition of data.



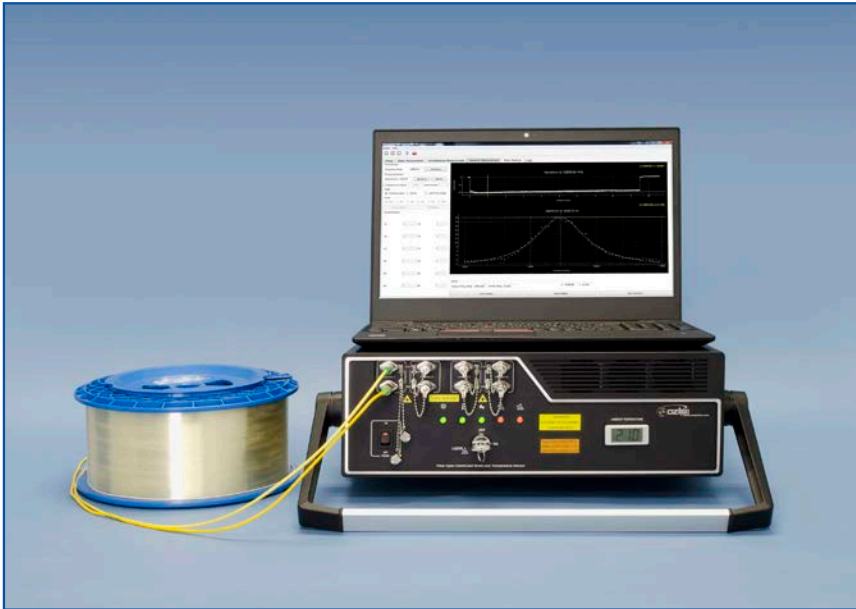

### 3U model with laptop computer

The 3U version of the DSTS comes with removable carrying handles. The user can easily replace the handles with tabs (sold separately) that will allow the unit to be installed in a standard 19-inch rack.

### Optional Accessories



Fiber fusion splicer - FSP-100-S/M



Precision fiber cleaver - FSP-100-CLV

### Related Products

#### Fiber Optic Sensor Probes, Components, Termination Kits, and Training

OZ Optics offers a full spectrum of fiber optic sensor probes, components, termination kits and training. OZ Optics' standard fiber optic products have been used worldwide in high performance sensor and telecommunications applications since 1985. OZ Optics also offers specialty fiber optic sensor probes and custom cabling for high temperature applications and other hostile and corrosive environments. System integrators with experience in structural and pipeline monitoring will find that OZ Optics offers a complete suite of enabling products and services for installing and maintaining fiber optic systems. If you are planning a pipeline or structural monitoring project, please contact OZ Optics to learn more about our fiber optic solutions.

For more information about our strain and temperature sensor system and related products, please visit [www.ozoptics.com](http://www.ozoptics.com).

### Questionnaire

1. What is your application? Please describe briefly.
2. Are you looking for a BOTDA module (requires both ends of fiber to be connected to DSTS) or a BOTDR module (requires only one end of fiber to be connected to DSTS) or a COMBO unit with both BOTDA and BOTDR functions?
3. What are your resolution and precision requirements for temperature measurements?  
Resolution: \_\_\_\_\_  
Precision: \_\_\_\_\_
4. What are the highest and lowest temperatures you expect?
5. What are your resolution and precision requirements for strain measurements?  
Resolution: \_\_\_\_\_  
Precision: \_\_\_\_\_
6. What is the maximum strain to be measured?
7. What is the desired sensing range or fiber length in this application?
8. What spatial resolution do you desire?
9. Do you want to measure temperature, strain or both?
10. What is the desired data acquisition time?
11. Do you need fiber calibration / system design / project engineering service?
12. Where will the unit be housed?
13. Do you need a portable model with a laptop computer or a 19" rack-mounted model with a laptop computer?
14. Any additional information?

Please email [sales@ozoptics.com](mailto:sales@ozoptics.com) for our recommendation about your requirements.