



MANUALLY ADJUSTABLE POLARIZATION INSENSITIVE VARIABLE BANDWIDTH TUNABLE FILTERS

PRELIMINARY SPECIFICATIONS

Features

- 45 nm tunable wavelength range
- 1 to 18 nm continuously adjustable bandwidth
- Independently tunable both wavelength and bandwidth
- Flat-top filter shape
- Available for wavelengths from 1100 nm to 1650 nm
- Polarization insensitive
- High resolution
- Singlemode, polarization maintaining, and multimode fiber versions
- High out-of-band suppression
- High input power handling

Applications

- WDM channel filtering
- High-speed transmission testing
- Signal filtering
- Laser pulse shaping
- ASE light noise suppression
- Tunable light sources
- Spectral analysis
- Fiber optic component manufacturing
- Quality control and measurement
- Product development

Product Description

The manually adjustable variable bandwidth tunable filter is a pig-tailed component with adjustment knobs that allow both the wavelength and bandwidth of the filter to be controlled. The device contains two independently variable tunable bandpass filters in series. With the two filters tuned to cover slightly different wavelength ranges, the overall passband becomes the region where the two individual passbands overlap. The amount of overlap determines the width of the filter. Since each filter can be tuned over a range of wavelengths, both the center frequency and width of the passband can be controlled.

Each individual filter consists of a multi-layer thin film band pass filter, designed to give a flat top pass band, with steep roll-off shapes. The center wavelength of the filters is adjusted by changing the angle of incidence of the light as it impinges upon the filter.

In the Variable Bandwidth Tunable Filter, each filter is independently rotated relative to the incoming light, in order to change the passband. OZ Optics uses a special technique to minimize polarization dependencies, allowing PDL effects to be kept below 0.3 dB, and making the spectral response virtually polarization independent. This feature makes it ideal for today's DWDM system applications.

Variable bandwidth tunable filters using singlemode, and Polarization Maintaining (PM) fibers are offered. In general, OZ Optics uses polarization maintaining fibers based on the PANDA fiber structure when building polarization maintaining components and patch cords. However, OZ Optics can construct devices using other PM fiber structures. We do carry some alternative fiber types in stock, so please contact our sales department for availability. If necessary, we are willing to use customer-supplied fibers to build devices.



Variable Bandwidth Tunable Filter

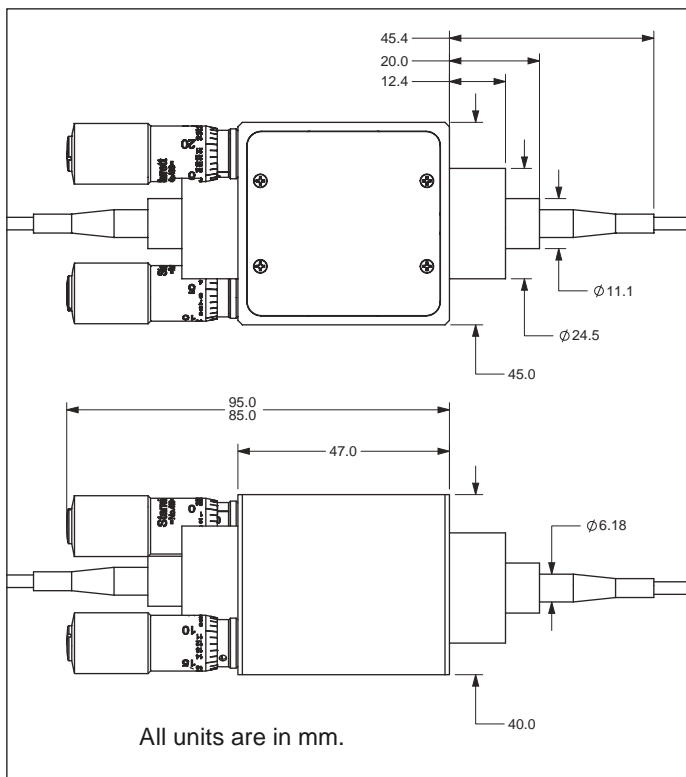

Ordering Information for Standard Parts

Standard Parts

Bar Code	Part Number	Description
56160	BTF-11-11-1525/1565-9/125-S-60-3S3S-1-1-1/18	Polarization insensitive manual variable bandwidth tunable filter for 1525–1565 nm with 1 meter long, 1mm OD jacketed 9/125 SM fiber pigtails, 60dB return loss, super FC/PC connectors, and 1–18 nm variable FWHM Fabry Perot filter.

Standard Product Specifications¹

Part Number	BTF-11-11-1525/1565-9/125-S-60-3S3S-1-1-1/18
Wavelength Range	1525 – 1565 nm; Other ranges available on request
Bandwidth (FWHM)	1 – 18 nm
Wavelength Resolution	0.1 nm
Filter Edge Roll Off Slope	10 dB/nm
Insertion Loss	3 dB for complete device over full tuning range
Polarization Dependent Loss (PDL)	Typically less than 0.3 dB
Transmission Shape	Flat-top
Wavelength/Temperature Sensitivity	0.002 nm/°C
Power Handling	Up to 200 mW for standard package
Fiber Type	SMF-28 (or SMF-28e)
Operating Temperature	-10° to 55°C
Storage Temperature	-30° to 70°C

¹ Typical values. Tested at 23°C.

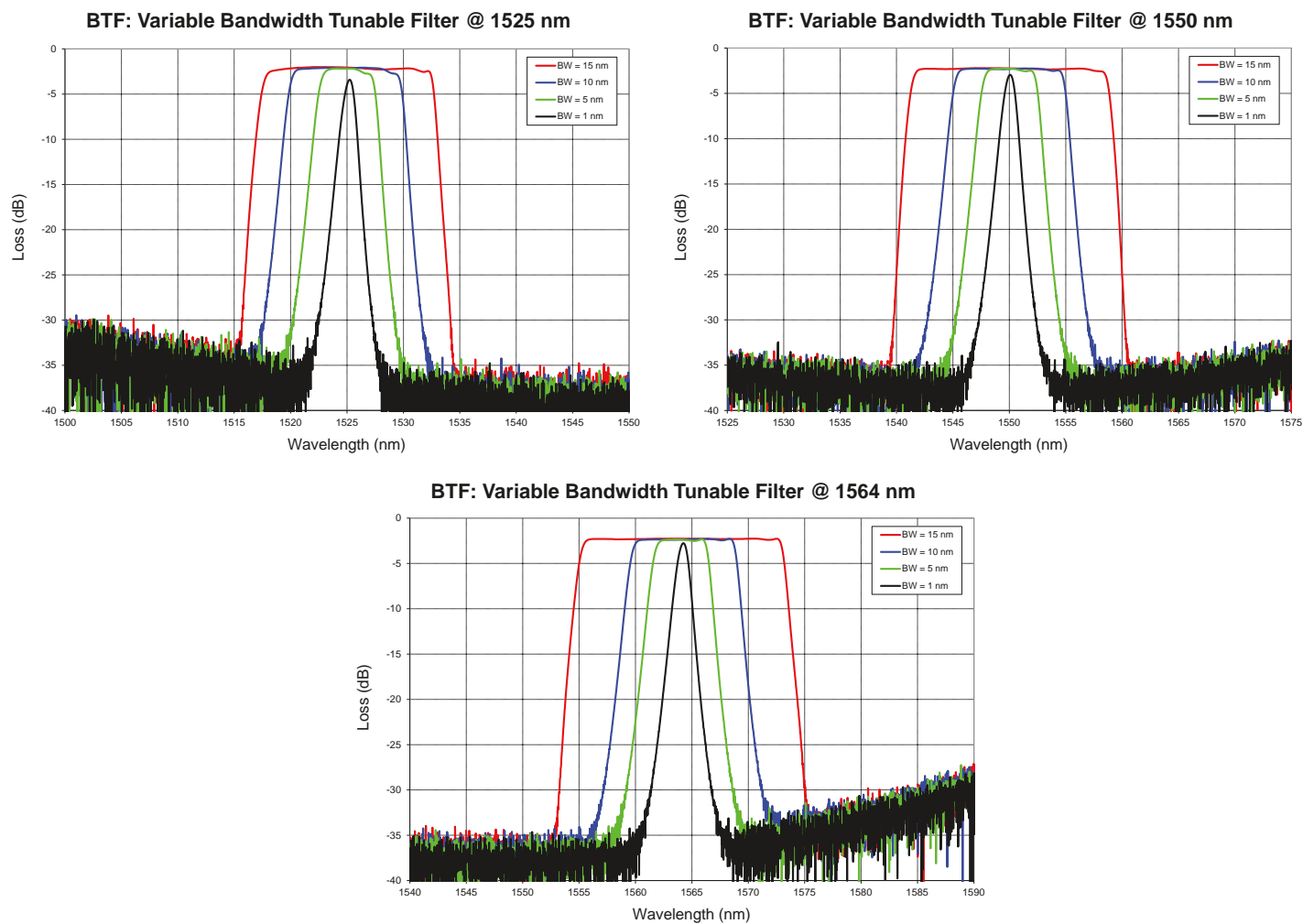

Figure 2. Typical transmission curves.

Ordering Example for Standard Parts

A customer wants a manual variable bandwidth tunable filter to filter ASE light noise from the transmitted advanced modulation format light signals, in order to test their characteristics at different DWDM channel frequencies. Those different modulation format signals have different spectral bandwidths and spectral shapes that are dependent on the modulation formats. The transmitted signal light is tapped out from the monitoring port with FC/PC receptacles and the wavelength regions of interest for the signals under test (SUT) are throughout the C-band. The transmitted light signals are polarized with random states of polarization (SOPs), and have different spectral bandwidths. Therefore, the filter required for the test should be polarization insensitive with an adjustable filter bandwidth, tunable across the entire C-band.

With this filter connected to the monitoring fiber from the DWDM network, the ASE noise light level can be reduced to a minimum for any spectral bandwidth signals without decreasing the signal intensity, i.e. to achieve a best OSNR for the transmitted light signals.

These requirements can be met with the part identified below:

Bar Code	Part Number	Description
56160	BTF-11-11-1525/1565-9/125-S-60-3S3S-1-1-1/18	Polarization insensitive manual bandwidth variable tunable filter for 1525–1565 nm with 1 meter long, 1mm OD jacketed 9/125 SM fiber pigtails, 60 dB return loss, super FC/PC connectors, and 1–18 nm adjustable FWHM Fabry Perot filter.

Ordering Information for Custom Parts

OZ Optics welcomes the opportunity to provide custom designed products to meet your application needs. As with most manufacturers, customized products do take additional effort so please expect some differences in the pricing compared to our standard parts list. In particular, we will need additional time to prepare a comprehensive quotation, and lead times will be longer than normal. In most cases non-recurring engineering (NRE) charges, lot charges, and a 1 piece minimum order will be necessary. These points will be carefully explained in your quotation, so your decision will be as well informed as possible. We strongly recommend buying our standard products.

Questionnaire for Custom Parts

1. What operation wavelength range are you interested in?
2. What variable bandwidth range do you require?
3. What type of fiber is being used? Singlemode, PM, or multimode fiber?
4. Are you using a polarized or randomly polarized light source?
5. What return losses are acceptable in your system?
6. What connector types are you using?
7. What fiber length and jacket diameter do you need?

Part Number ***BTF-11-11-W-a/b-F-LB-XY-JD-L-BW***

W = Wavelength range in nanometers:
Example: 1525/1565 for between 1525 and 1565 nm

a/b = Fiber core/cladding sizes in microns:
9/125 for 1300/1550 nm Corning SMF28 fiber
8/125 for 1550 nm PANDA style PM fiber

F = Fiber type:
S=Singlemode
P=Polarization Maintaining

LB = Backreflection level: 40, 50 or 60 dB for singlemode or PM fibers only. (60 dB for 1290 to 1620 nm wavelength ranges only)

BW = FWHM filter bandwidth range in nm
1/18 is standard. For other bandwidth requirements, contact OZ Optics.

L = Fiber length in meters

JD = Fiber Jacket type:
1=900 micron OD hytrel jacket
3=3mm OD Kevlar reinforced PVC cable

X.Y = Input & Output Connector codes:
3S=Super NTT-FC/PC
3U=Ultra NTT-FC/PC
3A=Angled NTT-FC/PC
8=AT&T-ST
SC=SC
SCA=Angled SC
LC=LC
LCA=Angled LC
MU=MU
X=No Connector

Ordering Example for Custom Parts

A customer wants to reduce the ASE light noise for transmitted signals using different spectral bandwidths, manually tuning the transmitted light wavelength between the C and L bands, (1550 to 1600 nm), and manually adjusting the transmitted light spectral linewidth from 1 nm to 18 nm.

A custom version of the manual variable bandwidth tunable filter will meet this requirement, as shown below:

Bar Code	Part Number	Description
N/A	BTF-11-11-1550/1600-9/125-S-60-3U3U-1-1-1/18	Polarization insensitive manual variable bandwidth tunable filter for 1550–1600 nm with 1 meter long, 1mm OD jacketed 9/125 SM fiber pigtails, 60dB return loss and ultra flat FC/PC connectors. Custom 1 – 18 nm FWHM Fabry Perot filter.

Frequently Asked Questions (FAQs)

Q: What is the filter bandwidth?

A: The standard variable bandwidth tunable filter has an adjustable bandwidth (FWHM) from 1 nm to 18 nm, consisting of two tunable bandpass Fabry-Perot type filters. This can be customized to suit the customer's requirements.

Q: What is the largest tuning range available?

A: The standard tuning range is 45 nm. However, the filter can be operated over a wider range with some effects on the insertion loss and polarization dependent loss in the shorter wavelength (high angle of incidence) region.

Q: How do you define your bandwidths?

A: Standard filters are specified by their Full Width Half Maximum (FWHM). This is the transmitted bandwidth at -3dB from the peak transmission. For custom filters, bandwidths such as the passband at -1dB and -25dB can be specified upon request.

Q: Is the shape of the transmission curve affected by the polarization?

A: No, OZ Optics tunable filters utilize an optical technique to control Polarization Dependent Losses (PDL). This design reduces PDL to a minimal level, while at the same time making the spectral response polarization insensitive.

Q: How well does the filter block unwanted wavelengths?

A: For the standard filters the typical operation wavelength is in the C-band (between 1530 nm and 1565 nm) with a light pass bandwidth from 1 nm to 18 nm. This type of filter is good for selecting any channel signals in a DWDM system or cleaning up the ASE noise from a broadband light source in the C-band. However, the filter may still transmit light at wavelengths significantly outside the operating wavelength range. For custom applications that require operation over different wavelength regions or different variable filter bandwidths, please contact OZ Optics.

Q: Is the unit calibrated?

A: No, the manual variable bandwidth tunable filter is a low cost, flexible solution to bandwidth adjustable tunable filter needs and is not calibrated due to its manual use. However, OZ Optics does take great care in the production of these units in order to meet or exceed the optical properties required by the customers.

Application Notes

Introduction To Thin Film Filters:

In many fiber-optic applications we need to use light with a specific frequency or wavelength (λ) and a specific linewidth. Although a laser may be an excellent source of monochromatic radiation, we might still need a source of light providing controlled, variable wavelength, and even variable linewidth. Variable bandwidth filters provide an effective means of transmitting a well-defined band of light while blocking unwanted wavelengths emanating from a broadband source. This is useful when dealing with DWDM/ ROADM signals, or advanced modulation signals.

OZ Optics' Variable Bandwidth Tunable Filter uses an innovative filter design to tune both filter wavelength and linewidth at the same time (Figure 3). As the angle of incidence changes, the range of wavelengths passing through each filter changes. By controlling the angle of each filter relative to the incoming light, the upper and lower limits of the passband can be controlled, creating a tunable filter with an adjustable passband.

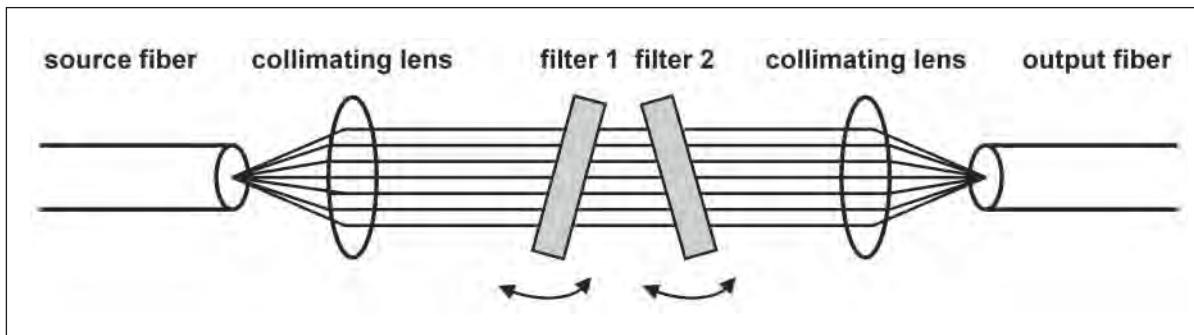

Figure 3. Conceptual design of a variable bandwidth tunable filter.

The typical output wavelength distribution is demonstrated in Figure 4. An adjustable linewidth is achieved by the light passing through common wavelength regions of the two bandpass filters. The spectral linewidth can be adjusted from 1 nm to 18 nm for a wavelength tunable range between 1525 and 1565 nm.

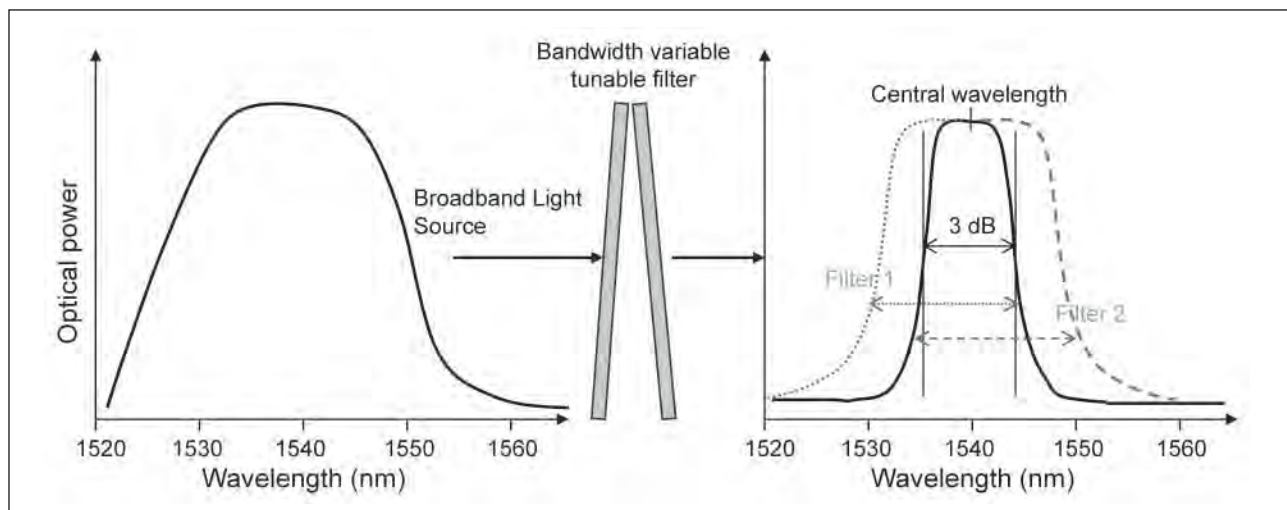

Figure 4. Use of a broadband light source and bandwidth variable tunable filter to generate a required narrow bandwidth signal.

A big problem with typical variable bandwidth tunable filters that has been solved by OZ Optics is their polarization sensitivity. As the angle of incidence increases, the sensitivity to polarized light also increases. (See Figure 5) This is a very important point in optical systems as the separation of the S and P polarization states causing a large PDL can have detrimental effects on the system.

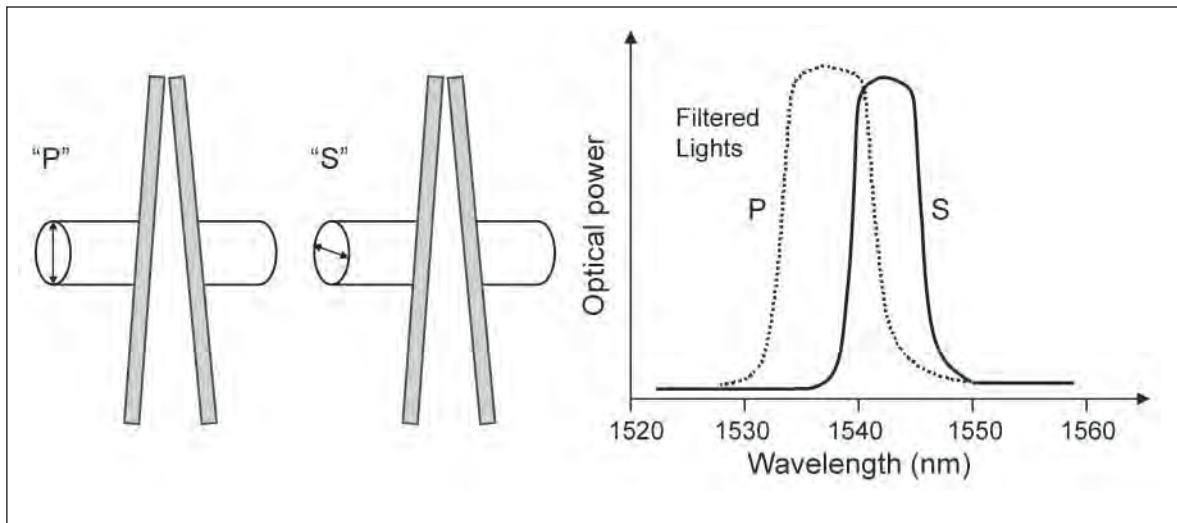

Figure 5. Differences in spectral linewidth and attenuation between “P” and “S” polarized lights.

OZ Optics' variable bandwidth tunable filters utilize an optical technique to control PDL making the spectral response polarization insensitive. The polarization insensitivity is accomplished through the precision alignment of optical components on both the input and output side of the filter. As demonstrated in Figure 6 below, the light is first split into its respective polarizations and then one of the polarizations is rotated such that the light incident on the filters is all the same polarization. After passing through the filters the other polarization is rotated and then the beams are combined for the final focusing and collection into the fiber. By rotating the light and having a common polarization pass through the filters the PDL effect of the filters at high angles of incidence is avoided. Therefore, the spectral response of S and P polarizations remain the same for increasing angles of incidence. See Figure 7.

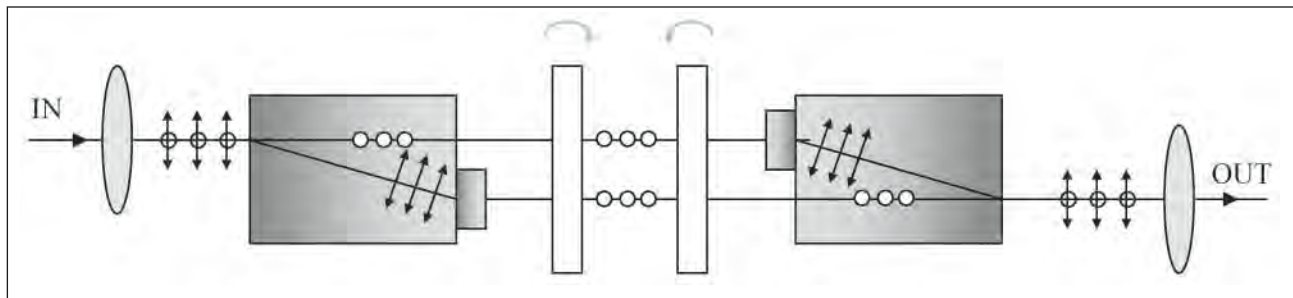

Figure 6. A perspective sketch showing the splitting and recombining of the polarizations in a variable bandwidth tunable filter.

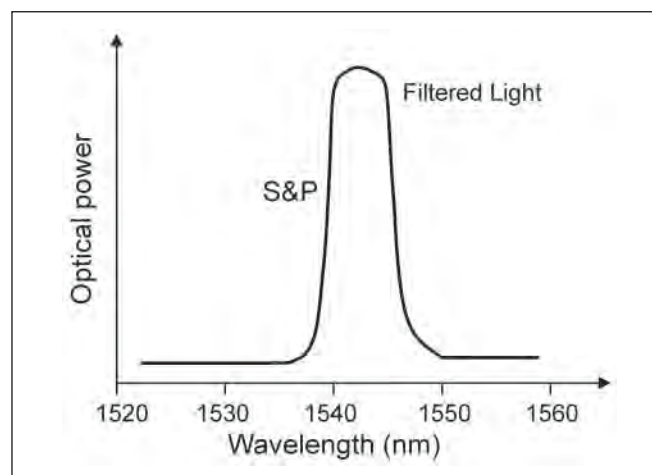

Figure 7. “S” and “P” polarization output light at a high incident angle in the OZ Optics filter.