



OZ Optics

shop.ozoptics.com
www.ozoptics.com

219 Westbrook Road
Ottawa, ON, Canada, K0A 1L0

Toll free: 1-800-361-5415
Telephone: 1-613-831-0981
Fax: 1-613-836-5089
sales@ozoptics.com

2D FIBER MATRIX ARRAY (2D FMA) ASSEMBLIES

PRELIMINARY

Features:

- Up to 12x12 Fiber Matrix arrays or other combinations based on the availability of substrate
- Singlemode, multimode or polarization maintaining fibers
- High polarization extinction ratios up to 30 dB available
- Individual fibers
- Assemblies with bare fiber or 900 μm jacketing, and with or without connectors
- 900 μm jacketed breakouts available, up to 2 meters in length
- Custom configurations possible for OEM applications
- Designed to meet Telcordia specifications (GR 1221-core, GR 326-core)

Applications:

- Optical Switching and Cross-Connection
- Biomedical Imaging
- Optical Sensors
- Switches
- Interferometry
- Integrated Components
- Connection to waveguide devices
- Spectroscopy and Astronomy

Product Description:

OZ Optics provides a wide range of 2D Fiber Matrix Arrays made from different types of fibers (single-mode, multi-mode, polarization maintaining, other) at any customer specified lengths. 2D fiber optic assemblies allow hundreds of channels to be positioned precisely in both X and Y directions simultaneously without crosstalk. Building on our expertise in 1D V-Groove fiber positioning, we align and polish the fibers to a very high end-face quality and required length tolerances. We guarantee precise output pigtail lengths suitable for interferometry applications.

Customization can even include different types of fibers assembled into matrix array. PM fibers offer a means to control the polarization of optical signals throughout the system thus minimize Polarization Dependent Losses (PDL) and Polarization Mode Dispersion (PMD) effects. This control is crucial in developing high speed 40 Gb/s to next generation 100 Gb/s coherent detection systems.

OZ Optics typically uses polarization maintaining fibers based on the PANDA fiber structure when building polarization maintaining components and patchcords. However, OZ Optics can construct devices using other PM fiber structures. We do carry some alternative fiber types in stock, so please contact our sales department for availability. If necessary, we are willing to use customer supplied fibers to build devices.

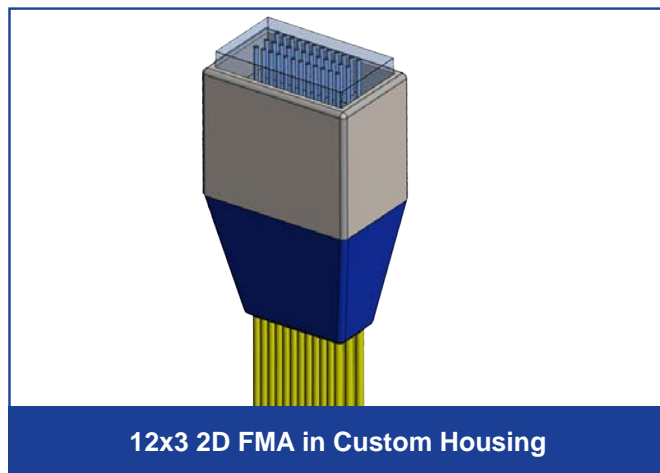

12x3 2D FMA in Custom Housing



12x3 PM 2D FMA Back Side

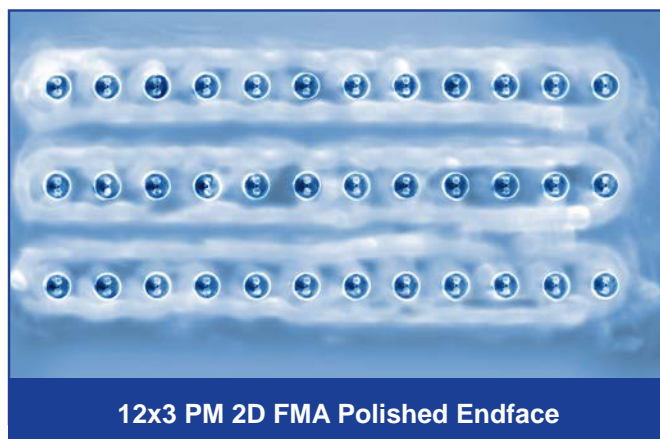

12x3 PM 2D FMA Polished Endface

Standard Product Specifications:

Number of Channels	2x2, up to 12x12 or Other	
2D matrix material	Fused Silica	
Fiber type	SM,MM	PM
Fiber pitch	X=250,500um; Y=500,750,1000um, Other	
Fiber Core Position Tolerance	<1um (typ)	
Fiber Size	125/250um	
Angle alignment (°)	±3 standard, 1.5 premium	
Extinction ratio (dB)	N/A	20, 25,30
Breakout Connector Type	FC, LC, SC, SMA, ST, E2000, MTP, Other	
AR coating	Available upon request	

Ordering Information For Custom Parts:

OZ Optics welcomes the opportunity to provide custom designed products to meet your application needs. As with most manufacturers, customized products do take additional effort so please expect some differences in the pricing compared to our standard parts list. In particular, we will need additional time to prepare a comprehensive quotation, and lead times will be longer than normal. In most cases non-recurring engineering (NRE) charges, lot charges, and a 50 piece minimum order will be necessary. These points will be carefully explained in your quotation, so your decision will be as well-informed as possible. We strongly recommend buying our standard products.

Questionnaire For Custom Parts:

1. How many fiber channels do you need (2x2, up to 12x12)?
2. What fiber spacing is needed for your application (X=250,500 um, Y=500,750,1000 um, Other)?
3. Do you need the endface polished at an angle (8° angle standard)?
4. What type of fibers do you need (singlemode, multimode, PANDA type polarization maintaining)?
5. Do you need connectors for the assembly?
6. How long of an assembly do you need?

FMA-N1xN2-S1xS2-A-D-VL-VW-VT-F-W-a/b-X-JD-L-B

N1xN2 = Number of V-Grooves
2x2, 4x4, 6x6, 8x8, 10x10, 12x12. Etc.

S = V-Groove Spacing (in microns)
X=250, 500
Y=500,750,1000, other

A = Angle of Polish
0, 8 degrees standard

D = Direction of angle
A,B,C,D, X for flat
polish (0°)

VL = Length (in millimeters)

VW = Width (in millimeters) See standard specifications for standard chip dimensions

VT = Thickness (in millimeters)

E = Fiber Type
S = Singlemode
P = Polarization Maintaining
M = Multimode

W = Wavelength of operation

a/b = Fiber Core/Cladding Diameter
9/125 for Corning SMF-28 SM fiber
6/125 for Corning Flexcore 1060 SM fiber
7/125 for 1300nm PANDA PM fiber
8/125 for 1550nm PANDA PM fiber

B = Breakout length (in meters)
2 meter maximum, 0.5 meter is typical

L = Overall Length (in meters)
Standard length is 1-2 meters

JD = Jacket Diameter
0.25 = bare fiber, 250 μm coated
0.40 = PM fiber with 400 μm coating (500 μm spacing only)
1 = 900 μm jacketed (Hytre)

X = Connector Code
Note: Standard Assemblies have the same connectors on all fibers
3S = Super FC/PC (<-40 dB RL)
3U = Ultra FC/PC (<-50 dB RL)
3A = Angled FC/PC (<-60 dB RL)
8 = ST
SC = SC (<-40 dB RL)
SCU = Ultra SC (<-50 dB RL)
SCA = Angled SC (<-60 dB RL)
LC = LC
LCA = Angled LC
MU = MU
X = No Connector

Frequently Asked Questions (FAQs):

Q: What are the standard materials used?

A: Fused Silica, other materials upon request..

Q: Can UV cure adhesives be used to attach the 2D Fiber Matrix Array assembly to a device?

A: Yes, The material allows UV curing of the assembly for attachment.

Q: What is the difference between alignment of the stress rods and alignment of the polarization axis for PM fibers?

A: The stress rods in PM fiber create a stress across the fiber core, producing the high birefringence that gives PANDA fiber the ability to maintain polarization. However this stress is not perfect throughout the fiber. In addition, the 2D Fiber Matrix Array production process causes some stress of its own, disturbing the stress profile. These stress variations cause the fiber polarization axis to vary slightly from the stress rod alignment by one or two degrees. Because the stress rods are monitored during alignment, they are specified to a tighter tolerance than the polarization axis.

Q: What is the breakout box for?

A: The breakout box is used to protect the transition from bare fiber to 900 μm jacketing. The breakout box is required for assemblies that are to be supplied with connectors.

Q: Does the breakout box add any attenuation to the 2D Fiber Matrix Array assembly?

A: No, the breakout box provides a means to separate and jacket the fibers without adding additional attenuation.

Q: Can the breakout leads have differing lengths or connectors?

A: Yes, OZ Optics can manufacture the breakout to custom specifications, including connector options or individual lengths.

Q: How close can the breakout box be to the 2D Fiber Matrix Array chip?

A: The minimum standard distance is 0.25 meters.

Q: Can test data be supplied with the 2D Fiber Matrix Array's?

A: Yes. If specified prior to ordering, OZ Optics can supply a test report for each 2D Fiber Matrix Array or a sampling of the lot being ordered. Please note that this may effect the lead time and price of the assemblies being ordered.